

| REV 更改号 | DATE 日期 | REVISION DETAILS 更改内容 | APPD 审核并批准 |
|------------|---------------|--------------------------|---------------|
| A | OCT. 10. 2020 | Production issue | |
| B | NOV. 18. 2020 | change Dia7.5 to Dia7.0 | Zhang |

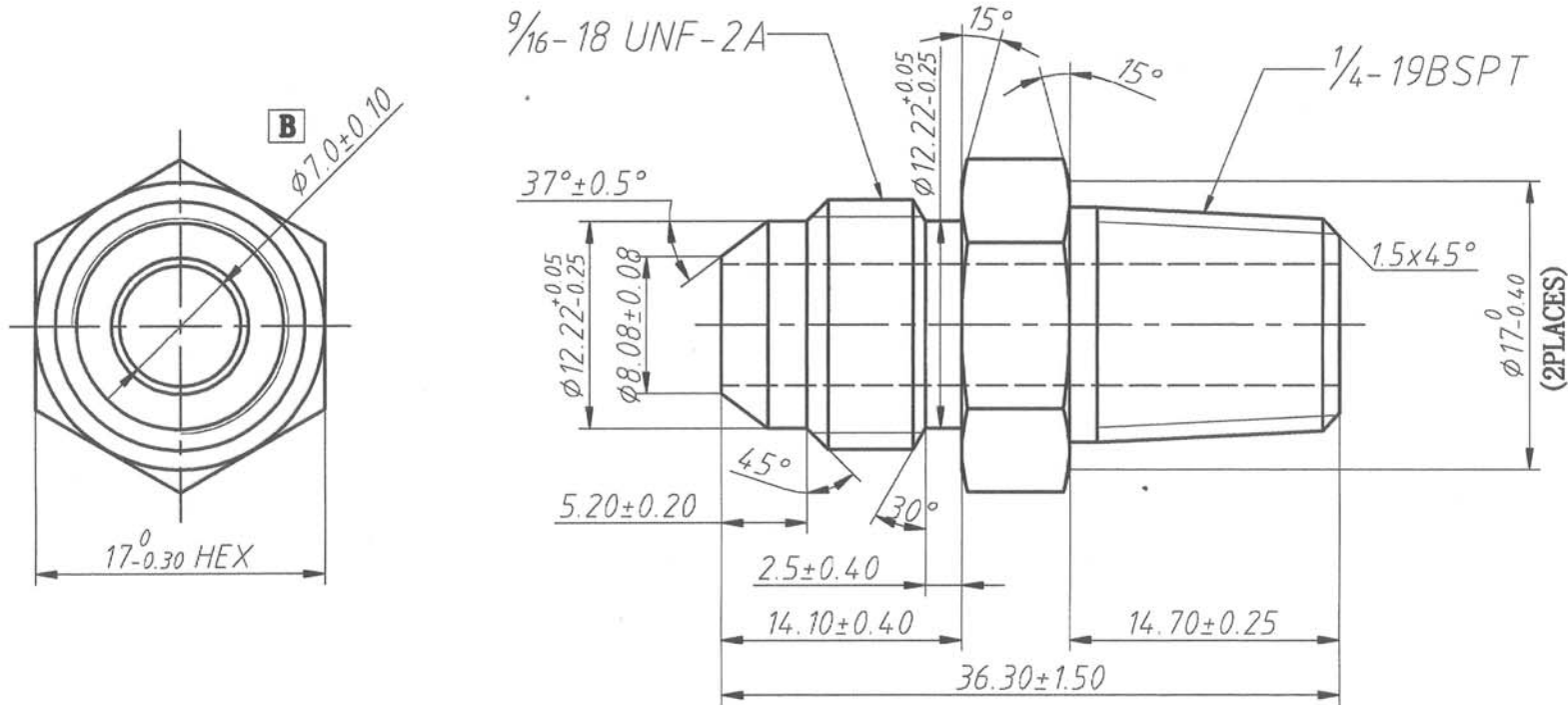

UNLESS SPECIFIED
ALL DIMENSIONS IN mm,
MACHINED SURFACES $Ra=3.2\mu m$,
ANGLE TOLERANCES $\pm 5^\circ$,
Other tolerance except angles,
in accordance with
GB/T1804-2000(ISO2768-1)-m
and GB/T1184-1996(ISO2768-2)-m

其它事项,
图示尺寸单位为mm,
未注机加工表面粗糙度 $Ra=3.2\mu m$,
未注角度公差 $\pm 5^\circ$,
其它未注公差(除角度外)均按:
GB/T1804-2000(ISO2768-1)-m 和
GB/T1184-1996(ISO2768-2)-m

Zhejiang Gaocheng Autoparts Co.,Ltd

PART No
零件名

41472-STR-6JIC-R4

SCALE:

APPD:
批准 Zhang

DRN:
制图 余德胜

NTS

DATE:
日期

CHK:
审核 詹永斌

2020.11.18

MATERIAL

Chinese steel 45

材质 45#

FINISH

Remove all sharp edges,burrs,slivers and swarf, break all edges 0.127-0.254mm.
ZINC PLATING WITH 6um MICRONS MINIMUM PLATING THICKNESS AND TRIVALENT CHROMATE PASSIVATION
AND WITHSTAND 96 HRS TO WHITE / 144 HS TO RED RUST IN SALT SPRAY TEST.

去除所有毛刺,铁屑等残留物,锐边倒钝0.127-0.254mm.
镀锌,三价铬钝化,银白色,盐雾试验96小时无白斑,144小时无红锈,镀锌层厚度大于6um.